

The Florida Senate
BILL ANALYSIS AND FISCAL IMPACT STATEMENT

(This document is based on the provisions contained in the legislation as of the latest date listed below.)

Prepared By: The Professional Staff of the Committee on Regulated Industries

BILL: SB 1220

INTRODUCER: Senator DiCeglie

SUBJECT: Air-conditioning Systems

DATE: March 24, 2025

REVISED: _____

	ANALYST	STAFF DIRECTOR	REFERENCE	ACTION
1.	Baird	Imhof	RI	Pre-meeting
2.			CA	
3.			RC	

I. Summary:

SB 1220 expands the scope of Class A air-conditioning contractors relating to the installation and repair of package pool heaters, pipe connecting, and other specific pool related jobs.

The bill also provides an annual inflation increase for the current exemption from notice of commencement and applicability of lien requirements that apply to direct contracts replacing or repairing existing heating or air-conditioning systems that cost less than \$15,000.

The bill provides an effective date of July 1, 2025.

II. Present Situation:

Class A Air-Conditioning Contractors

Construction contractors are regulated under ch. 489, F.S. A licensed contractor, under this chapter, is defined as an individual, that for compensation, undertakes, bids on, or executes construction repair, alteration, remodeling, demolition, or improvement projects on buildings or structures, consistent with the job scopes outlined in s. 489.105, F.S.

Construction contractors are either certified or registered by the Construction Industry Licensing Board (CILB) housed within the Department of Business and Professional Regulation (DBPR). The CILB is responsible for licensing statewide construction contractors and regulating the construction industry in Florida under part I of ch. 489, F.S.¹

Currently, there are four types of Heating, Ventilation, and Air-Conditioning (HVAC) contractors:²

¹ Section 489.107, F.S.

² Section 489.105(3), F.S.

- Class A air-conditioning contractor:
- Class B air-conditioning contractor:
- Class C air-conditioning contractor:
- Mechanical contractor.

The scope of work for “Class A air-conditioning contractors” specifically includes services that are unlimited in the execution of contracts requiring the experience, knowledge, and skill to install, maintain, repair, fabricate, alter, extend, or design central air-conditioning, heating, and ventilation systems and to perform other related tasks including replacing, disconnecting, or reconnecting electrical wiring up to an electrical panel and disconnecting and replacing breakers or fuses dedicated to HVAC circuits.³

HVAC contractors are not allowed to install or remove pool water heaters, pool equipment, pool piping, or construct pool/spa equipment rooms. However, they are authorized to service and repair pool heaters as long as such service or repair does not include installing or removing the pool heater.⁴

Pool/Spa Contractors

There are over 7,000 certified pool/spa contractors with current active licenses in the state of Florida.⁵ A certified and licensed swimming pool/spa contractor, as defined within s. 489.105, F.S., is a professional authorized by the DBPR to engage in the construction, repair, and servicing of swimming pools and spas. Pool/spa contractors are divided into three categories: commercial pool/spa contractor, residential pool/spa contractor, and swimming pool/spa servicing contractor.

Generally, the scope of work for the commercial and residential pool/spa contractors includes activities like equipment installation, interior finishing, construction of equipment rooms or housing for pool/spa equipment, and *the installation of package pool heaters*.⁶

Pool Circulation System

A pool’s circulation or hydraulic system includes the elements of a pool that take water from the pool, filter it, heat it, and return it back into the pool. These elements include:⁷

³ Section 489.105(3)(f), F.S.

⁴ Licensing Board, Declaratory Statement 2012-024, available at https://www2.myfloridalicense.com/pro/cilb/documents/ds_2012-024.pdf (last visited March 24, 2025), Declaratory Statement 2014-006, available at https://www2.myfloridalicense.com/pro/cilb/documents/ds_2014-006.pdf (last visited March 24, 2025), Declaratory Statement 2014-060, available at https://www2.myfloridalicense.com/pro/cilb/documents/ds_2014-060.pdf (last visited March 24, 2025).

⁵ Florida Department of Business and Professional Regulation, *Verify A Licensee*, available at <https://www.myfloridalicense.com/wl11.asp?mode=0&SID=> (last visited March 24, 2025).

⁶ Section 489.105(3)(j), F.S.

⁷ Capitol Pools. Understanding the Pool Circulation System, <https://www.capitolpool.com/service/operating-poolcirculation#:~:text=Your%20pool%E2%80%99s%20circulation%20system%20is%20the%20elements%20of,and%20what%20you%20need%20to%20do%20with%20them> (last visited March 24, 2025); R&R Pools, What Causes Poor Pool Circulation <https://www.rrpools.ca/blog/causes-poor-pool-circulation/> (last visited March 24, 2025).

- Water Outlets – these include any pool opening, such as skimmers, drains, and vacuum ports, where water is taken out of the pool and into the circulation system.
- Circulation Pump – the pump is responsible for pulling water out of the pool, through the circulation system, and back into the pool.
- Filter – cleans the water by removing dirt, debris, and bacteria from the pool water. Water is directed through the filter via a valve.
- Heater – heats the pool water and may include bypass valves⁸, which allow water to bypass the heater.
- Returns – these are openings in the pool through which water flows back into the pool from the circulation system.

A pool's flow rate is the speed at which the water travels through the circulation system, and the turnover time is the time it takes for the volume of water in the pool to make one pass through the circulation system.⁹

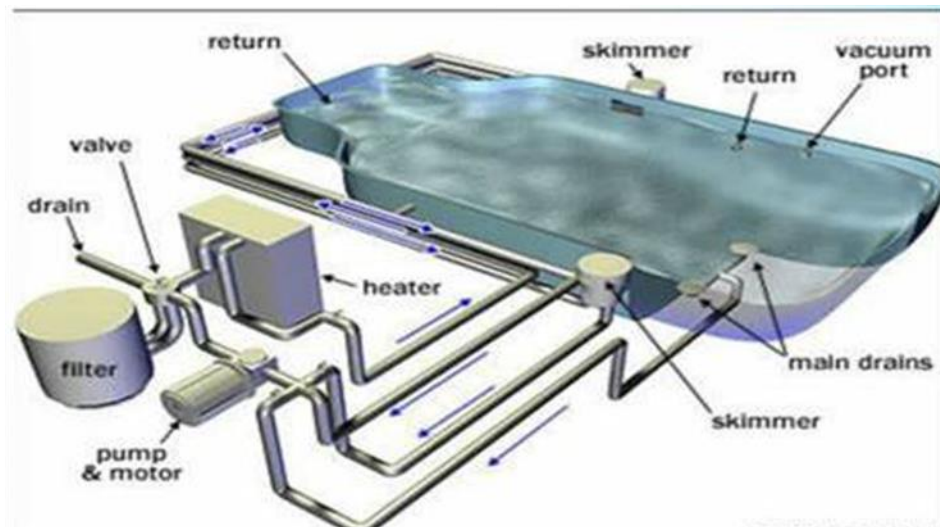

Pool Heaters

Generally, the pool's circulation system pulls water from the pool and into the pool heater, which warms the water via a heat exchange, and then circulates the heated water back into the pool. There are three main types of pool heaters: electric heat pumps, gas pool heaters, and solar pool heaters.¹⁰

⁸ Swimmingpoolsteve, *What is a Pool Heater Bypass?*

<https://www.swimmingpoolsteve.com/pages/bypass1.html#:~:text=An%20external%20bypass%20is%20a%20configuration%20of%20pool,your%20breakpoint%20chlorination%20to%20remove%20spent%20chlorine%20%28c> (last visited March 24, 2025).

⁹ Stockwell Safety, *Flow Rate and Turnover*, [https://www.stockwellassociates.co.uk/tutorial-flow-rate-and-turnover.php#:~:text=Flow%20rate%20refers%20to%20the,litres%20per%20minute%20\(LPM\)](https://www.stockwellassociates.co.uk/tutorial-flow-rate-and-turnover.php#:~:text=Flow%20rate%20refers%20to%20the,litres%20per%20minute%20(LPM)). (last visited March 24, 2025).

¹⁰ Scott Keller, *How Does a Pool Heater Work: A Comprehensive Guide to Pool Heating Options and Efficiency*, Love Gunite Pool, (September 18, 2024) <https://lovegunitepool.com/how-does-a-pool-heater-work/> (last visited March 24, 2025); Hank Cooper, *How Gas Pool Heaters Work? Unveiling the Science behind Your Warm Swim* (July 26, 2024)

Exemption from a Notice of Commencement

A notice of commencement must be filed before beginning certain construction projects in Florida.¹¹ Generally, a notice of commencement is recorded in a county's public records to establish the project's start date and serves to protect owners from paying twice for the same work by clearly identifying the parties involved. The notice of commencement also serves to provide contact information for potential lienors in the case of contractual disputes or other legal action.

Currently, there is an exemption from notice of commencement and applicability of lien requirements for direct contracts replacing or repairing existing heating or air-conditioning systems that cost less than \$15,000.¹²

III. Effect of Proposed Changes:

Section 1 of the bill amends the scope of work for a "class A air-conditioning contractor" to include "the installation and repair of package pool heaters and the connection of package pool heaters to existing pool piping; the installation, repair, or replacement of existing or new pool/spa equipment, or cleaning or sanitizing equipment that requires at least a partial disassembling."

The bill would not allow class A air-conditioning contractors to do "filter changes; interior finishes; the installation of all perimeter piping and filter piping; and the construction of equipment rooms or housing for pool/spa equipment."

Section 2 of the bill would require that \$15,000 amount be adjusted and increased annually by the percent change in the Consumer Price Index for All Urban Consumers, U.S. City Average, All Items, 1982-1984=100, or successor reports.

Sections 3, 4, 5, 6, and 7 are reenacted for the purposes of incorporating the amendments made by the bill.

Section 8 of the bill provides an effective date of July 1, 2025.

IV. Constitutional Issues:

A. Municipality/County Mandates Restrictions:

None.

B. Public Records/Open Meetings Issues:

None.

<https://pooltipsusa.com/how-gas-pool-heaters-work-unveiling-the-science-behind-your-warm-swim/> (last visited March 24, 2025).

¹¹ Section 713.135, F.S.

¹² Section 713.135(1)(f), F.S.

C. Trust Funds Restrictions:

None.

D. State Tax or Fee Increases:

None.

E. Other Constitutional Issues:

None.

V. Fiscal Impact Statement:

A. Tax/Fee Issues:

None.

B. Private Sector Impact:

The bill expands the scope of work of Class A air-conditioning contractors, potentially increasing the amount of business they can contract for.

The bill allows Class A air-conditioning contractors to contract for work that pool/spa contractors can already do, potentially having a negative impact on pool/spa contractors' business.

C. Government Sector Impact:

None.

VI. Technical Deficiencies:

None.

VII. Related Issues:

In Section 2 of the bill, it is not clear what agency would be charged with making the inflation adjustments.

VIII. Statutes Affected:

This bill substantially amends sections 489.105 and 713.135 of the Florida Statutes.

The bill reenacts sections 489.107, 489.113, 489.117, 489.141, and 553.998 of the Florida Statutes.

IX. Additional Information:

- A. **Committee Substitute – Statement of Changes:**
(Summarizing differences between the Committee Substitute and the prior version of the bill.)

None.

- B. **Amendments:**

None.

This Senate Bill Analysis does not reflect the intent or official position of the bill's introducer or the Florida Senate.
